

Mixer specifically for sealing material required for caulking work at construction site.
Lightweight and durable. Prevents construction error with high luminance LED display.

The lightest in the industry!! Exclusively for sealing material Container Rotating Mixer

KARUMAZE

⊕ Use
Exclusively for sealing material



POINT 1 Lightweight unit is easy to carry!!

The lightest in the industry weighing only 9.4kg(※)
Reduces load at construction site.
※Weight includes exclusive resin vanes.



POINT 2 Digital panel of easy operation!!

Digital panel that is easy to see in dark places.
Function that announces when mixing is complete.



POINT 3 Using high-functioning resin that is shock-resistant!!

Light and durable resin vane exclusive for this unit.
Evenly mixes high-viscosity material.



HARD MIXER SERIES [KARUMAZE]

Dimensions / Part Names (Unit: mm)

- ① Dedicated resin vane
- ② Mixing vane entry area
- ③ Mixing vane storage area
- ④ Rotary tank holder
- ⑤ Holder lock (Adjustable)
- ⑥ Timer UP button
- ⑦ Timer DOWN button
- ⑧ Timer display
- ⑨ Reservation mode button
- ⑩ Mixing mode button
- ⑪ Mixing mode button
- ⑫ Start/Stop button (Long press to reset)
- ⑬ Carry arm

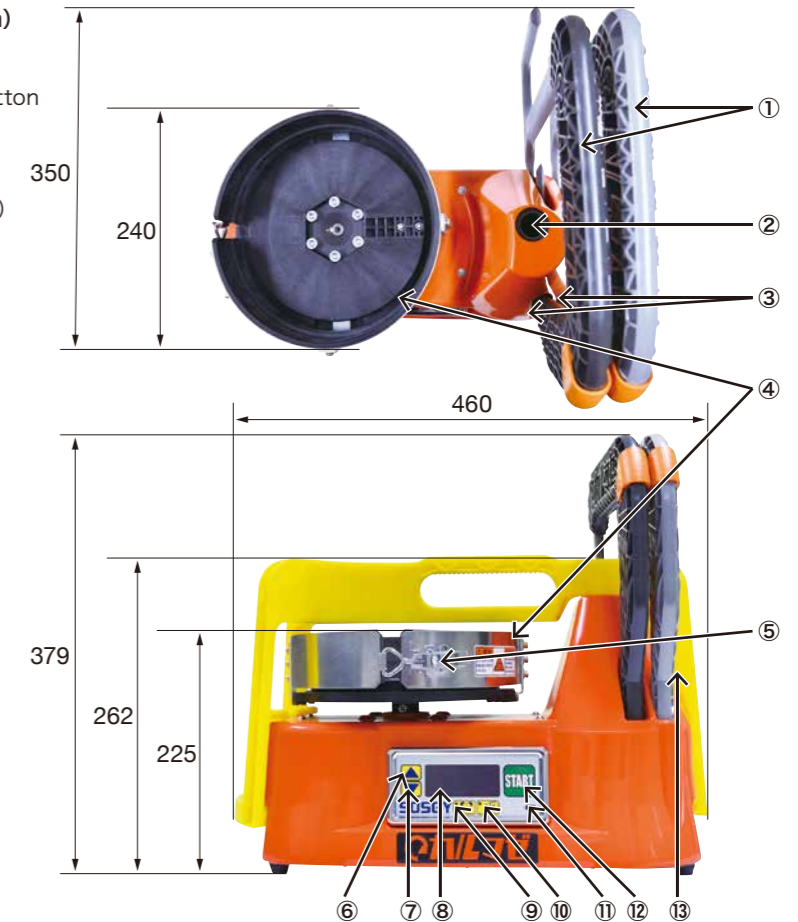

- **Stable mixing available throughout Japan!**
The unit can be used in all power frequency regions (50Hz area/60Hz area)
- **Compatible with former models!**
Iron vanes and container holders of former model LR-II/AR-II can be used.
- **Comes with carrier arm for transport**
The unit can be carried with one hand into the construction site



Attention: The resin vane can only be used for KARUMAZA.

Standard Specifications

Attachable container	Sealing can φ217 only
Mixing vane	Comes with 1 resin vane each (4L/6L)
Power supply/Electric capacity	100V・5A
Mixing motor	100W
Container rotation speed/direction	Fixed speed (50Hz/60Hz:45rpm)/Automatic reversed rotation
Timer	Digital type, reservation 0-999 minutes
Weight	mixing 1-99 minutes (initial setting: 15 minutes)
	9.8kg (including mixing vane and carry arm)

※Specifications and outside appearance may change without advanced notice.
※The device is not explosion- or water-proof.
※Special specifications other than those noted above are available (optional).
Please inquire with our sales representative if you wish to add optional specifications.

Option

